

Sliders · JSK SL

Advantages at a glance

- Low weight
- Suitable for all standard hole pattern types
- Optimum protection against corrosion thanks to E-coating

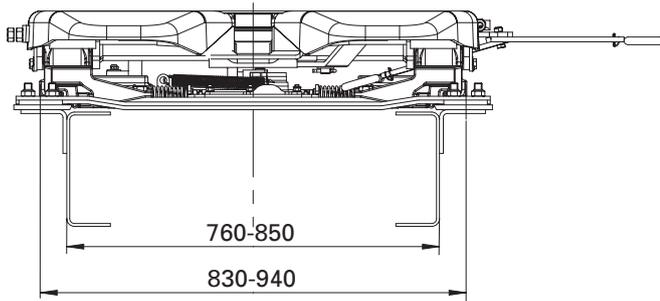

V = Sliding distance

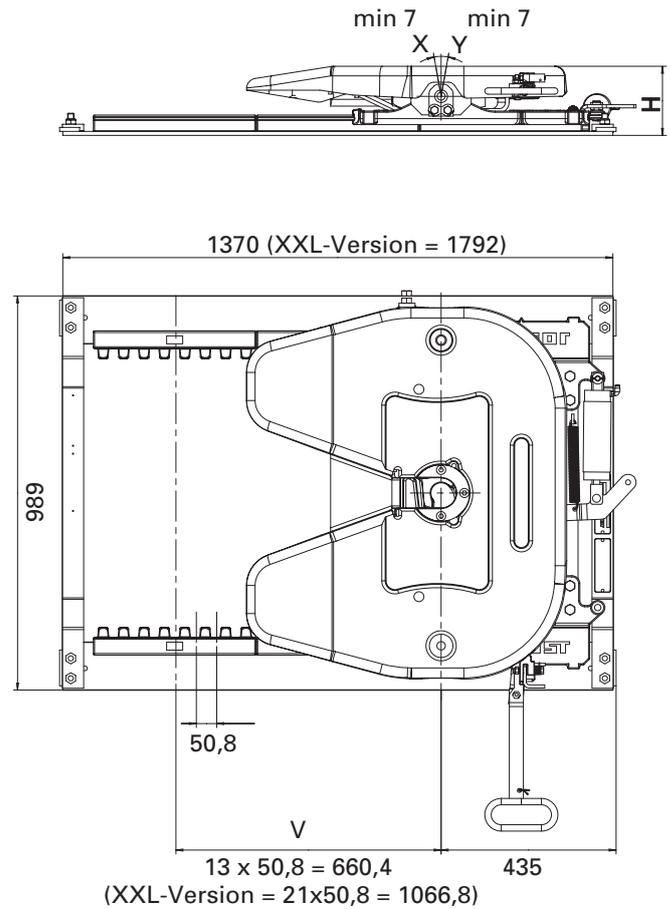

Technical Data

Type	D value (kN)	Imposed load U (t)	Approval (ECE SL)
JSK SL	152	20	E1 55R-01 1151

Installation instructions under www.jost-world.com

- The JSK SL is not suitable for use in site traffic.
- The load conditions apply for operation on paved roads and transport conditions typical in Central Europe.
- Please enquire about uses other than these.

Technical Specification

Suitable for 2" king pins (class G 50) as per ECE R55-01, DIN 74080, ISO 337 and steering wedges as per ECE R55-01, DIN 74085.

Order key for JSK SL

Components and variants

Fifth wheel coupling JSK SL	Mounting height	Variants Handle / SK-Maintenance	Customer hole pattern types (all e-coated)
DO = JSK 36 D (pressed steel)	32 = 173 mm	06 = Slider manual	AA = Standard (without hole pattern, no customer-specific pattern)
EO = JSK 37 E (cast)	45 = 203 mm	07 = Slider manual/JSK 37 EW	FV = IVECO hole pattern 920/M16
	73 = 263 mm	T6 = Slider manual/JSK 37 EW/LT1P	DR = DAF hole pattern 880/M16/150/100/200
		D6 = Slider manual/JSK 36 D + 3 Sensors*	CK = MAN hole pattern 880/M16
		20 = Slider pneumatic	TS = DAF hole pattern 880/M16
		21 = Slider pneumatic/JSK 37 EW	CN = RVI hole pattern 900/M16
		I3 = Slider pneumatic/JSK 37 EW/LT1P	DV = RVI hole pattern 940/M16
		D5 = Slider pneumatic/JSK 36 D + 3 Sensors	EC/GA = Scania hole pattern*** 880/M18/reinforced traverse
		V2 = Slider pneumatic/JSK 37 E/1 Sensor on Slider**	BC/GC = Scania hole pattern 880/M18
		X6 = XXL Slider manual	BD = Volvo hole pattern 930/M12
		X4 = XXL Slider manual/JSK 37 EW/LT1P	DF = JOST hole pattern XXL Slider 880/M16
		X8 = XXL Slider pneumatic	
		X5 = XXL Slider pneumatic/JSK 37 EW/LT1P	

* = remote display and cable set have to be ordered seperatly

** = only avaiable in mounting heights 173 mm and 203 mm with customer hole pattern type GA/GC

*** = reinforced traverse only possible with elevated mounting angle

XXL-Slider only with "AA" or "DF" hole pattern

Explanations:

JSK 37 EW = Low-maintenance version with plastic top plate liner

LT1P = LubeTronic 1Point

Example of an order number – JSK SL DO 32 06 AA

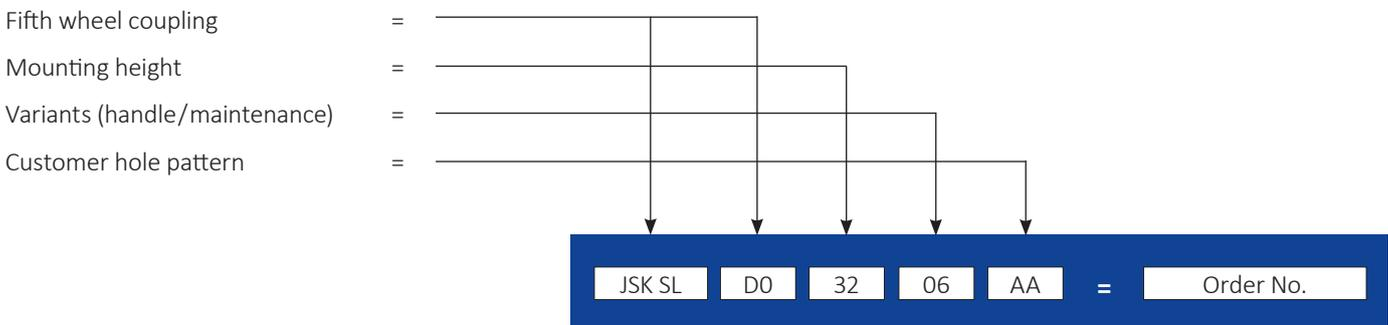

Mounting kits

Customer hole pattern	Order No.	Quantity per SL
CT/FV	SLE000000120	1
CK	SLE000000120	1
CN/DV	SLE000000120	1
BP	SLE000000120	1
CP/DR/TS	SLE000000120	1
DF	SLE000000120	2
BD	SLE000000320	1
EC/BC	SLE000000220	1
CB	SLE000000720	1

Remote display

Order No.	Description	Weight (kg)
SKE501620200	3-sensor-display, 24 V (european Standard)	0,075
SKE501620500	3-sensor-display, 12 V	0,075

Cable set

Order No.	Description	Weight (kg)
SKE002110200	ADR (for hazardous materials transporter)	1,85

Fleetmaster Handle

Order No.	Description	Weight (kg)
SKE070616469	complete for slider manual	2,00
SKE070616416	complete for slider pneumatic	2,00

available with

Delivery time on request (not all combinations are possible)

Customer hole pattern

FV

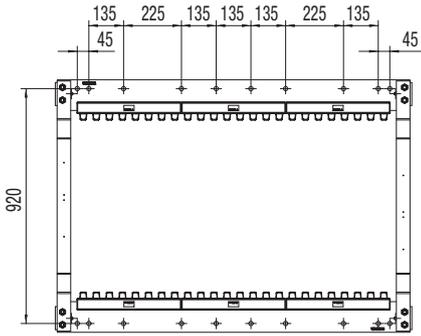

DR

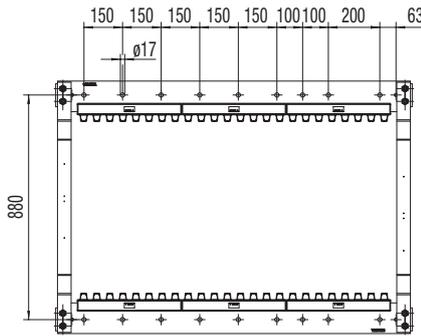

TS

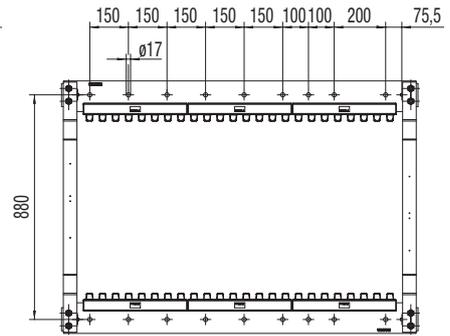

CK

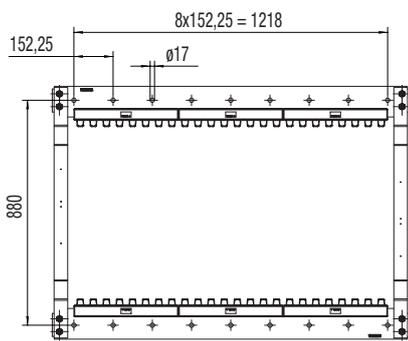

CN

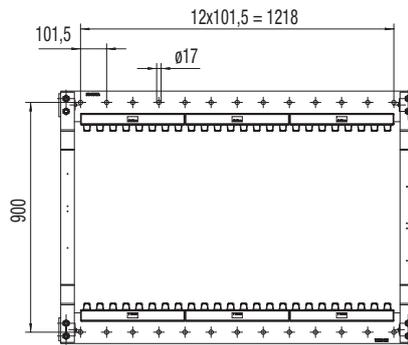

DV

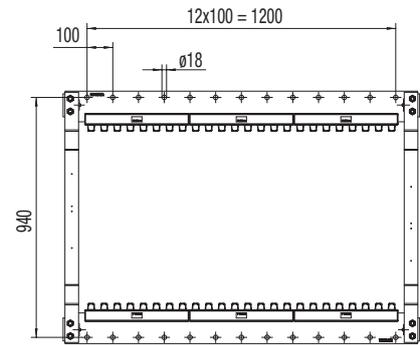

EC/GA/BC/GC

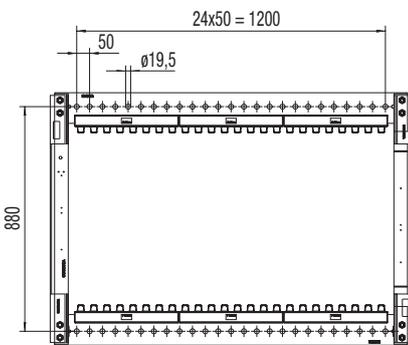

BD

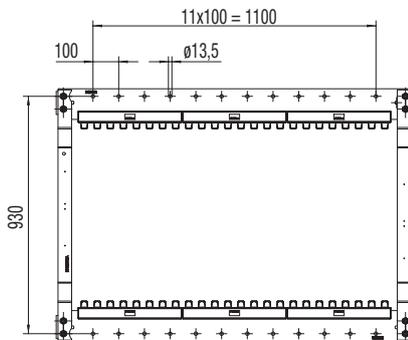

DF

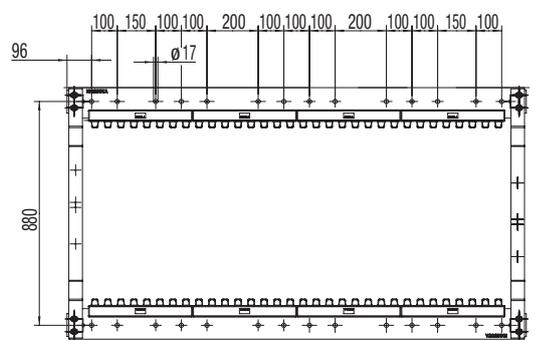

JSK SL

Spare parts

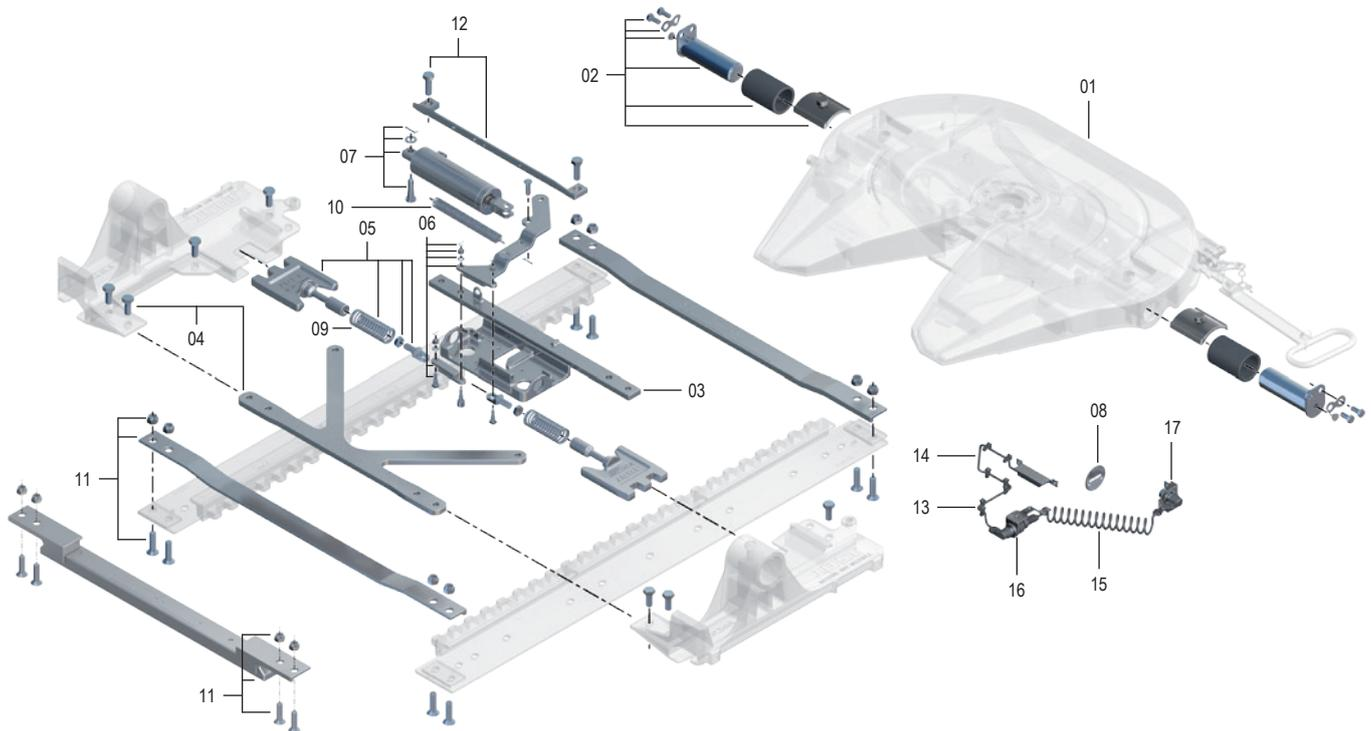

Item	Description	Remark	Order No.	per JSK	Item	Description	Remark	Order No.	per JSK
01	Fifth wheel coupling	*		1	oZ	Handle, kit BH 203	for manual version	SLE202850020	1
02	Bearing	for JSK SLEOxxxxx	SK 3121-61	1	oZ	Handle, kit BH 220	for manual version	SLE202850020	1
02	Bearing	for JSK SLDOxxxxx	SK 2921-051	1	oZ	Handle, kit BH 263	for manual version	SLE202720020	1
03	Bearing, kit		SLE202210020	1	12	Bridge, kit	for manual version	SLE202770020	1
04	Bracing, kit		SLE202120020	1	12	Bridge, kit	for pneumatic version	SLE203300020	1
05	Stopper, kit	with 09	SLE202520020	2	12	Bridge, kit	for JSKSLxxxV2xx	SLE205070120	1
06	Lever, kit		SLE202300020	1	13	Cable tie	for JSKSLxxxV2xx	NTE004050000	7
07	Cylinder, kit	for pneumatic version	SLE202410020	1	14	Sensor kit	for JSKSLxxxV2xx	SKE002331100	1
08	Pneumatics kit	for pneumatic version	V 1021-54	1	15	Coiled cable	for JSKSLxxxV2xx	SLE203810100	1
09	Pressure spring		SLE201330020	2	16	Plug holder, Bearing plate kit	for JSKSLxxxV2xx	SLE203790000	1
10	Double tension spring	for pneumatic version	SLE202610000	1	17	Plug holder, traverse, kit	for JSKSLxxxV2xx	SLE203930000	1
10	Double tension spring	for manual version	SLE202950096	1	oZ	Support for lift sensor, kit	for JSKSLxxxV2xx	SLE203780000	1
11	Traverse, kit		SLE201380020	2	oZ	Elbow lever with magnet	for JSKSLxxxV2xx	SLE203820000	1
11	Reinforced traverse, kit Scania		SLE201380320	2					
oZ	Handle, kit BH 173	for manual version	SLE202420020	1					

* Spare parts of fifth wheel coupling see JSK 37 E or JSK 36 D
The gear racks and the fifth wheel plate are not available as spare parts.